

HYDRASUB 25

2-1/2" Submersible Centrifugal Pump

The HYDRASUB 25 is a robust hydraulic submersible pump designed for heavy-duty dewatering and fluid transfer tasks. Built for durability, portability, and efficiency, this compact 2.5-inch centrifugal unit delivers impressive performance with flow rates reaching 430 GPM (97.6 m³/h) and heads up to 97 feet (30 m). Its versatility makes it suitable for use in agriculture, industrial operations, marine environments, and OEM system integration, ensuring reliable operation under challenging conditions.

Crafted from anodized, high-strength aluminum and featuring a stainless steel impeller for superior corrosion resistance, the pump is engineered to withstand harsh environments. The gerotor-style hydraulic motor operates quietly and efficiently, and its ability to run dry without damage adds to its reliability – making it an excellent choice for applications where ease of use and consistent performance are critical.

SPECIFICATIONS:

Discharge	2-1/2" NPT with A-type cam and groove fitting included
Materials of Construction	Aluminum
Flow	Up to 430 GPM (97.6 m ³ /h)
Head Feet	Up to 97' (30 m)
Impeller	3.90" (99.06 mm) stainless steel
Drive Options	Hydraulic motor .45 cu. in. (7.37 cm ³) Hydraulic motor .58 cu. in. (9.5 cm ³)
Max Solid Size	Up to 1/2" (12.7 mm)
Features	<ul style="list-style-type: none">• Carrying handle provided• Compact, lightweight design• Corrosion resistant• Pumps down to a depth of 3/4" (19 mm)• Quiet operation with gerotor motor• Self-priming, can run dry without damage

Application:

- Agricultural
- Industrial
- Marine
- OEM



12500 South Pulaski Road
Alsip, IL 60803, USA
Phone (800) 563-8006



An Ingersoll Rand Business

HYDRASUB 25

PERFORMANCE CURVES

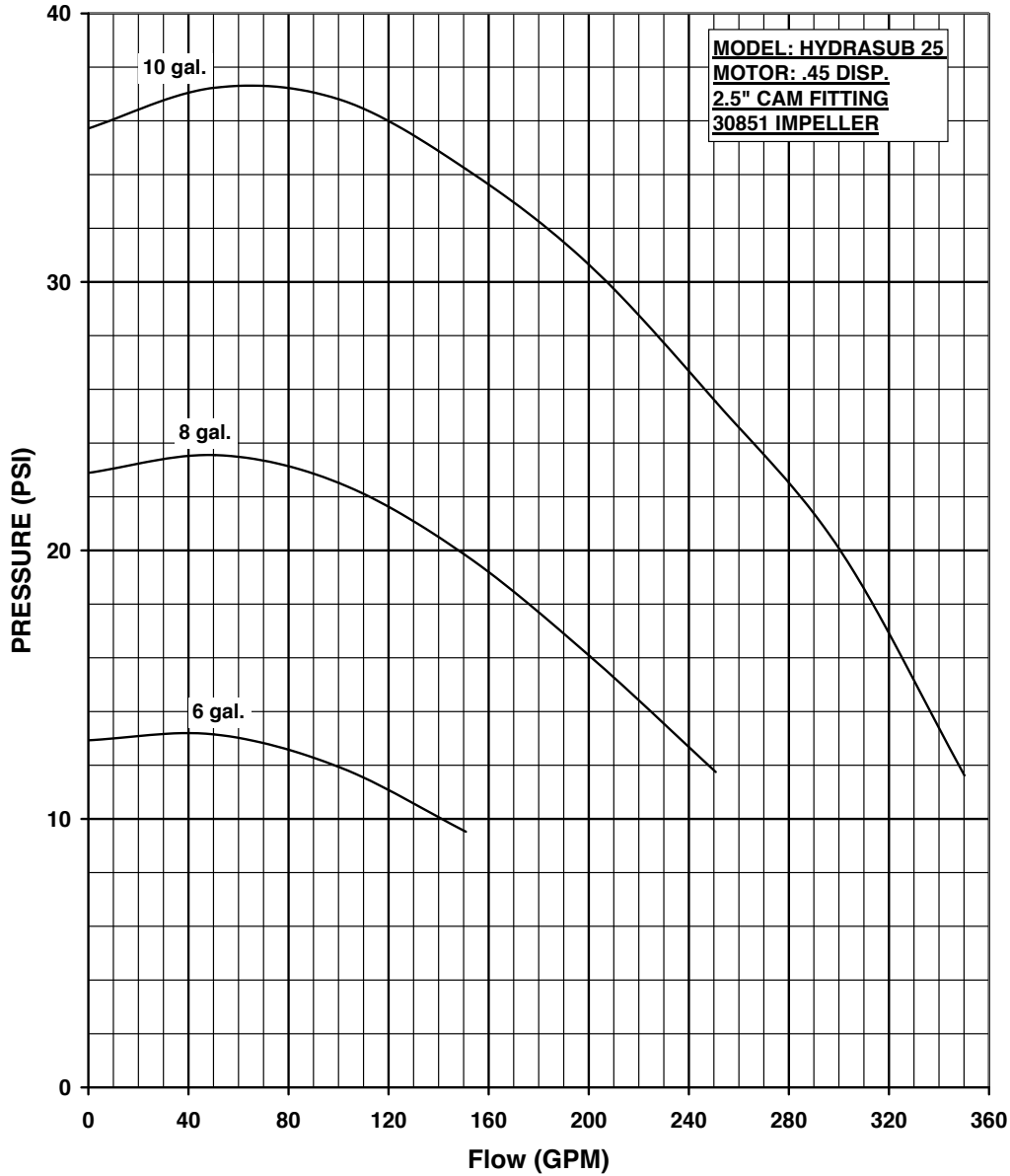

OIL FLOW	SHUT OFF	40	80	120	160	200	240	280	320	360	MAX. HYD. OIL PRESS. REQ.
	0 GPM	GPM	GPM	GPM	GPM	GPM	GPM	GPM	GPM	GPM	
6 GPM	13 PSI	13 PSI	13 PSI	12 PSI							850 PSI
8 GPM	23 PSI	24 PSI	23 PSI	22 PSI	19 PSI	17 PSI	12 PSI				1500 PSI
10 GPM	36 PSI	38 PSI	37 PSI	36 PSI	34 PSI	31 PSI	27 PSI	23 PSI	17 PSI		2150 PSI

CN 7099-S



12500 South Pulaski Road
 Alsip, IL 60803, USA
 Phone (800) 563-8006



An Ingersoll Rand Business

HYDRASUB 25

PERFORMANCE CURVES

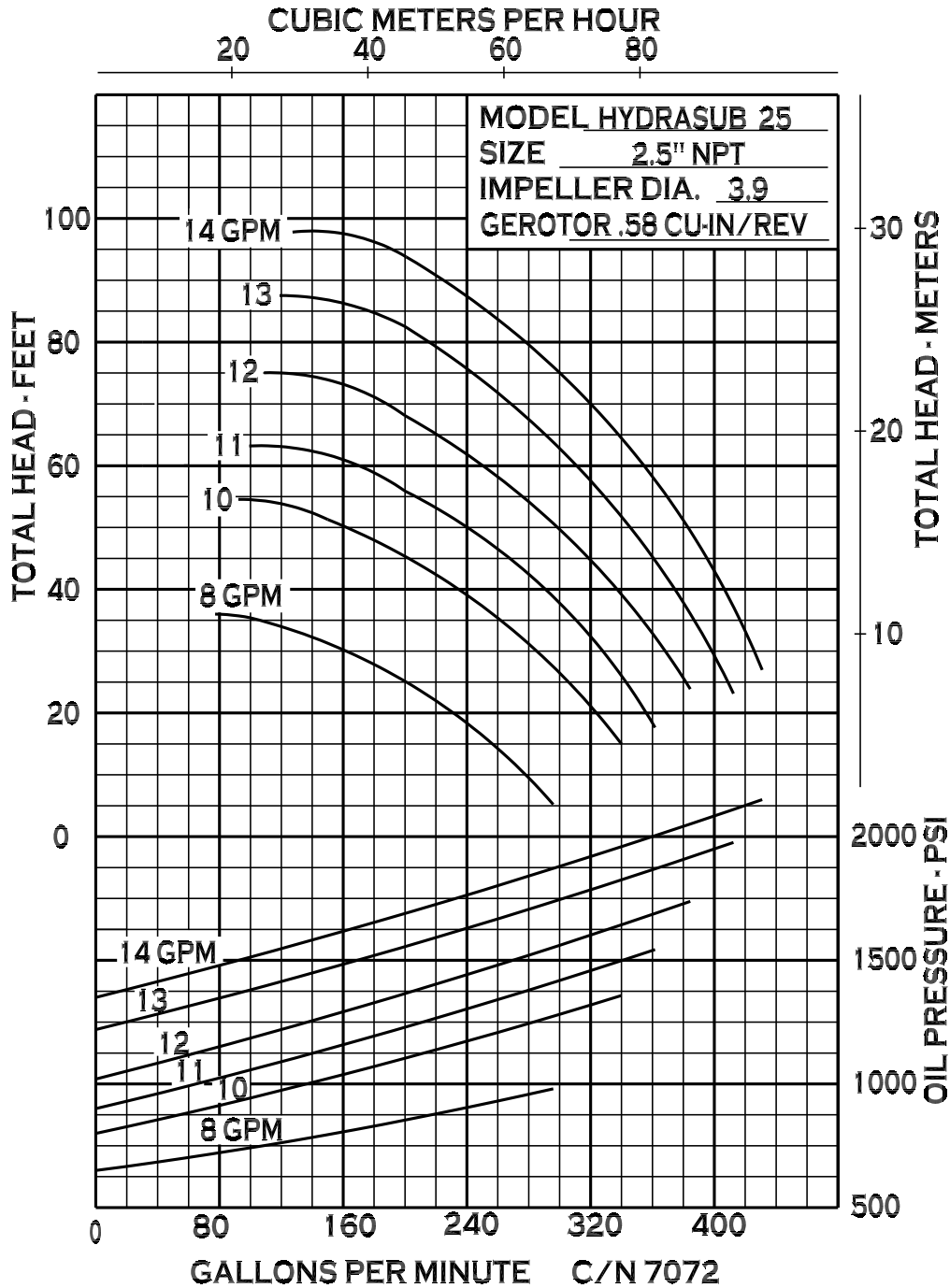

12500 South Pulaski Road
Alsip, IL 60803, USA
Phone (800) 563-8006



An Ingersoll Rand Business

HYDRASUB 25

PERFORMANCE CURVES

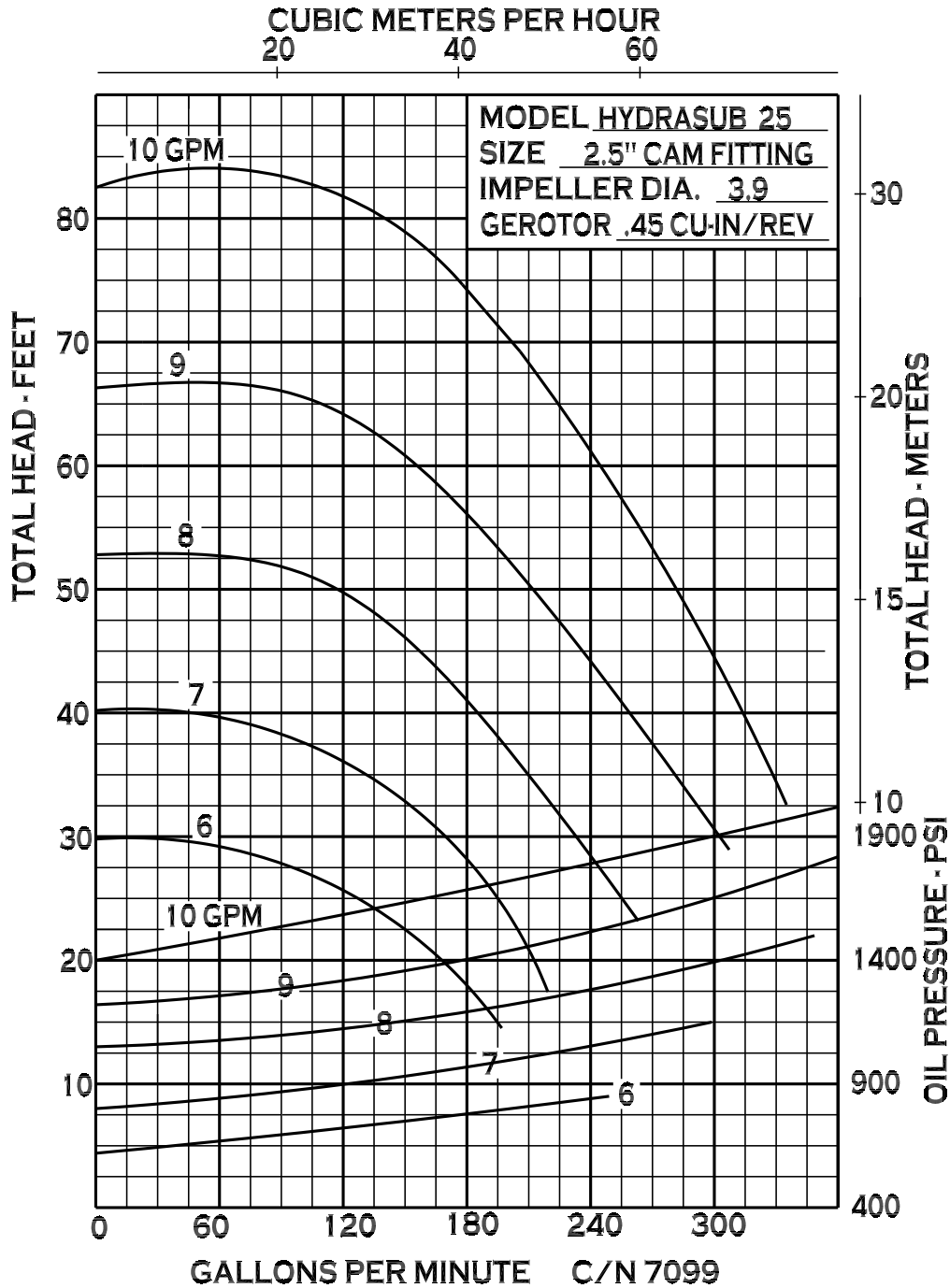

12500 South Pulaski Road
Alsip, IL 60803, USA
Phone (800) 563-8006



An Ingersoll Rand Business

HYDRASUB 25

DIMENSIONS

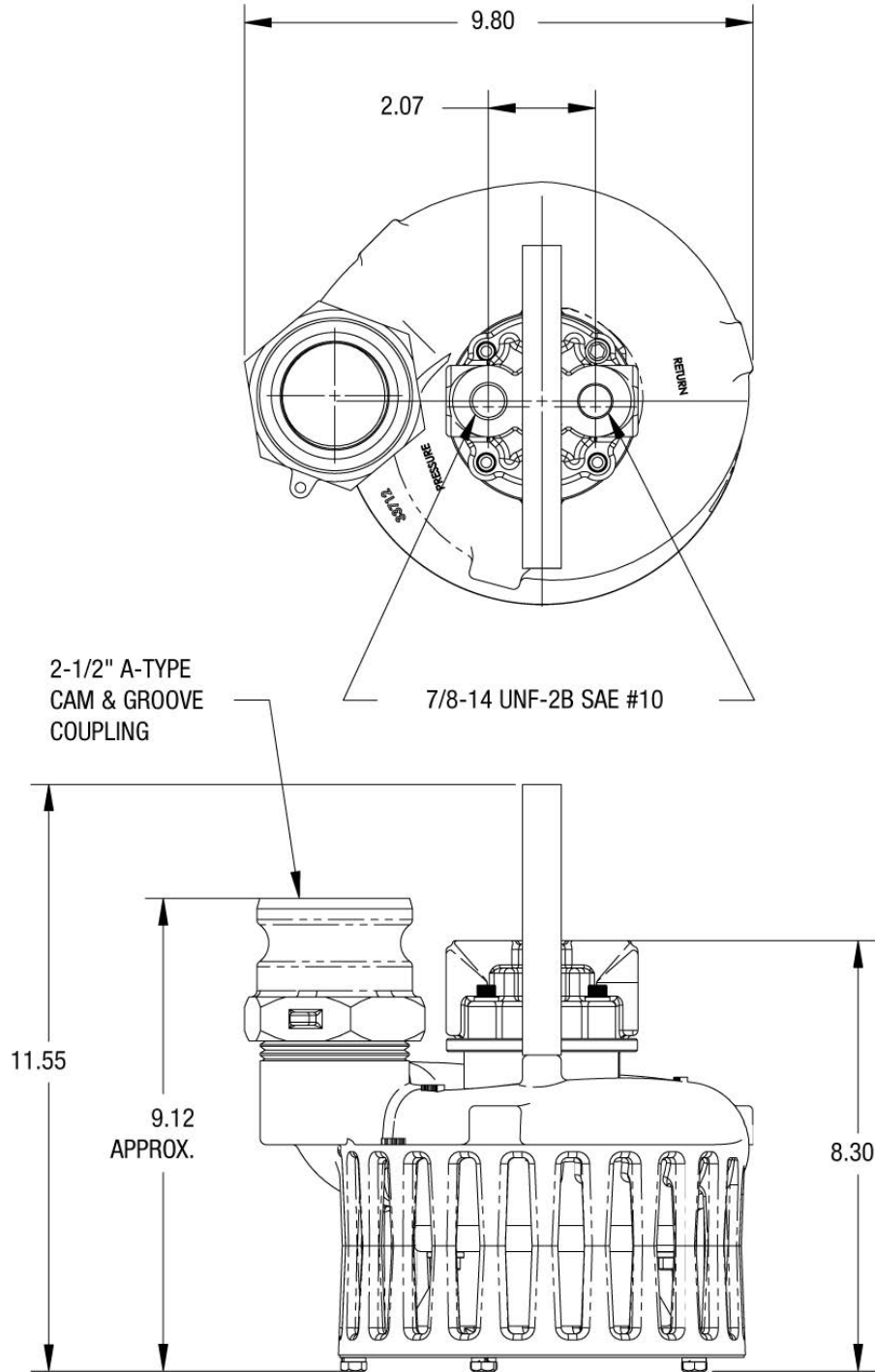

* For complete parts lists and troubleshooting guidance, please refer to the MP Pumps Installation Operation & Maintenance (IOM) Manual.



12500 South Pulaski Road
Alsip, IL 60803, USA
Phone (800) 563-8006